

SC550 SC550GL

Flat Panel Floor Cart For 32" to 47" Displays

The Peerless-AV® SC550 and SC550GL Flat Panel Floor Cart is designed to provide the ideal display viewing position, centralize audio video components and match the décor of any environment - boardrooms, training rooms, lobbies, classrooms, auditoriums, or exhibit halls. Internal cable management hides the AV cabling, showing a clean, clutter-free look.



FEATURES

- Compact design offers personalized computing and video conferencing
- Universal mounting pattern from 200 x 100mm up to 710 x 405mm
- Display tilt adjustment of +15°/-5° for desired viewing angle
- Height adjustable display mounting without the use of tools located anywhere along the column
- Height adjustable tempered glass shelf for AV components and accessories
- Integrated cable management protects, contains and conceals cables for a clean, professional installation
- 2" (51mm) swivel casters with two locking casters
- Assembly hardware included



Display size: 32" to 47"



Max load

Display: 125lb (56.7kg)

Shelf: 25lb (11.3kg)

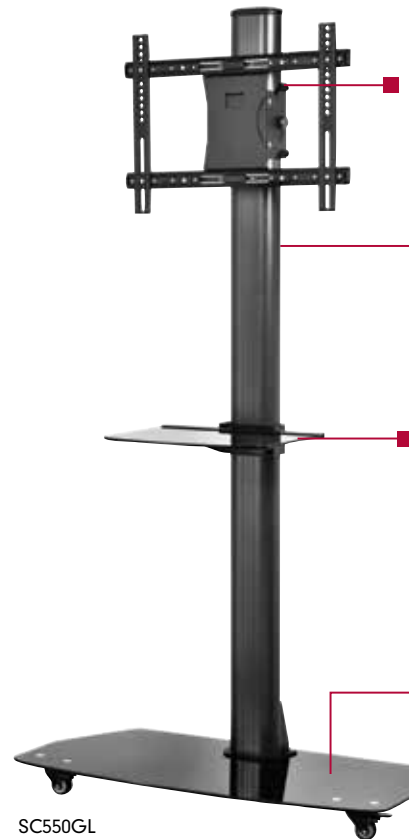

SC550GL

TOOL LESS HEIGHT ADJUSTMENT

Height adjustable display mounting without the use of tools and can be located anywhere along the column

INTEGRATED CABLE MANAGEMENT

Protects, contains and conceals cables for a clean, professional installation

COMPONENT PLACEMENT

Adjustable tempered glass shelf for AV components and accessories

SLEEK AND STYLISH

1/2" (13mm) tempered glass base to meet local building codes and safety requirements



SC550

RoHS
2002/95/EC

Model Numbers

WARRANTY: Limited 5-year

SSC550	Flat Panel Floor Cart for 32" to 47" Displays
SC550GL	Flat Panel Floor Cart for 32" to 47" Displays

Product Specifications

	DIMENSIONS (W x H x D)	PRODUCT WEIGHT	LOAD CAPACITY	FINISH	AVAILABLE COLORS
SC550	34.65" x 79.00" x 25.98" (880 x 2007 x 660mm)	93.3lb (42.3kg)	Display: 125lb (56.7kg) Shelf: 25lb (11.3kg)	Powder Coat	Black
SC550GL	39.37 x 79.38" x 19.69" (1000 x 2016 x 500mm)	75.6lb (34.3kg)			

Package Specifications

	PACKAGE SIZE (W x H x D)	PACKAGE SHIP WEIGHT	PACKAGE UPC CODE	PACKAGE CONTENTS	UNITS IN PACKAGE
SC550	Box 1: 73.5" x 9.5" x 6" (1867 x 241 x 152mm) Box 2: 35.6" x 27.4" x 3.35" (904 x 696 x 85mm)	104.3lb (47.1kg)	735029277095	Cart, tinted glass shelf, adaptor plate, assembly and display attachment hardware	1
SC550GL	Box 1: 73.5" x 9.5" x 6" (1867 x 241 x 152mm) Box 2: 41" x 21.5" x 3.75" (1041 x 546 x 95mm)	85.5lb (38.7kg)	735029277101		

All dimensions = inch (mm)

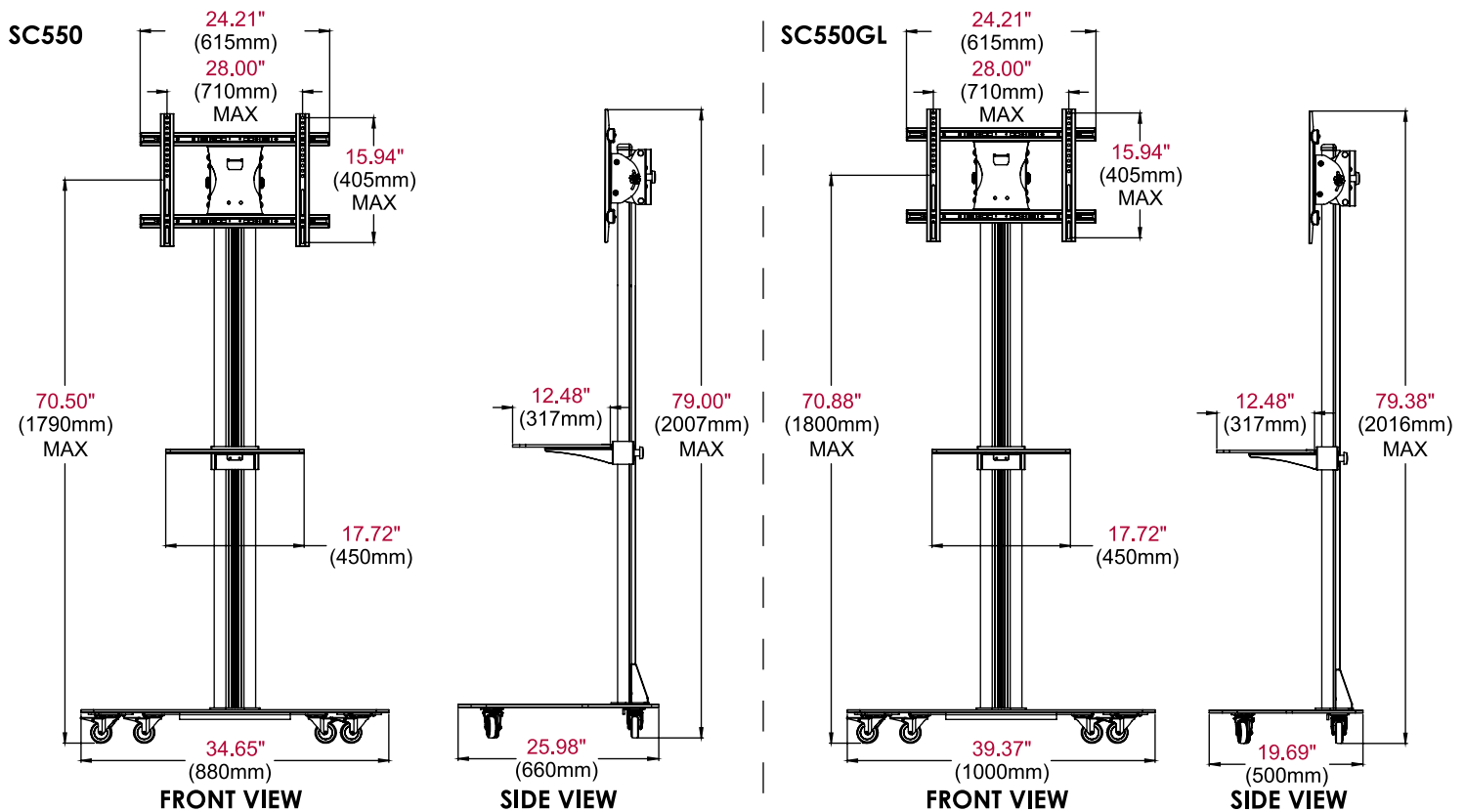

ARCHITECTS SPECIFICATIONS

Flat Panel Floor Cart shall be Peerless-AV models SC550/SC550GL and shall be located where indicated on the plans. It shall have a 125lb load capacity with a 25lb max for the shelf. It shall be finished in black. Assembly and installation shall be done according to instructions provided by the manufacturer.

Peerless Industries, Inc. ■ 2300 White Oak Circle ■ Aurora, IL 60502 ■ (800) 865-2112 ■ (630) 375-5100 ■ Fax: (800) 359-6500 ■ peerless-av.com

Visit peerless-av.com to see the complete line of AV solutions from Peerless-AV, including flat panel mounts, projector mounts, carts/stands, furniture, cables, screen cleaners and a full assortment of accessories.